

COMBINATION AIR VALVE BARAK, MODEL D-43 2"

INSTALLATION

1. The D-43 combination air valve should be installed vertically on a riser on the crown of the pipeline.
2. An inlet isolating valve should be installed underneath the D-43 air valve.

PERIODIC MAINTENANCE

- Routine service is an integral part of the standard procedure for maintenance of a water supply system.
- Recommended routine maintenance - at least once a year, according to the type and quality of the liquids in the system.

PROCEDURE (Fig. 1, 2)

1. Shut the Isolating Valve under the air valve before servicing.
2. **WARNING** – Slowly turn the valve Body (3) counterclockwise to release internal pressure from the air valve. Continue turning to remove the air valve from the service valve.
3. Wash the threaded area of the air valve Body under running water to remove accumulated debris from the threaded area of the lower air valve Body.
4. Manually unscrew the Float Lock (5) and remove it from the air valve Body.
5. Remove the Float and Seal Assembly (4) by sliding it out from the air valve Body.
6. Wash the Float and Seal Assembly thoroughly under running water, paying special attention to the Air Release Orifice (Fig.2), the Air Release Rolling Seal (4b) and the Air & Vacuum Seal (4a).
7. Visually examine the Air Release Rolling Seal and the Air & Vacuum Seal for any cracks or tears. If found, replace the entire Float and Seal Assembly unit. **
8. Manually verify free and unhindered movement between the Upper Component and the Lower Component of the Float and Seal Assembly (Fig. 2). Clean the slots of any debris that might cause interference.
9. Manually unscrew and remove the Discharge Outlet (1) from the air valve Body. Thoroughly wash the Discharge Outlet and the air valve Body under running water. Remove all debris from the Discharge Outlet screen.
10. Manually screw the Discharge Outlet tightly into the air valve Body.
11. Slide the Float and Seal Assembly into the air valve body, Upper Component side first (Fig. 2).
12. Manually screw the Float Lock into the air valve Body tightly till the end.
13. Wash the threaded area of the Service Valve.
14. Manually screw the D-43 Air Valve on the Isolating Valve and turn tightly till the end.
15. Slowly open the Isolating Valve.

** The Float and Seal Assembly unit can easily be replaced in the field.



 The old Float and Seal Assembly unit should be recycled in an approved Recycle Container for plastic materials.

PARTS LIST

No. Part

- | | |
|-----|--------------------------|
| 1. | Discharge Outlet |
| 2. | O-Ring |
| 3. | Body |
| 4. | Float and Seal Assembly |
| 4a. | Air & Vacuum Seal |
| 4b. | Air Release Rolling Seal |
| 5. | Float Lock |
| 6. | Upper Drain Outlet |

Fig. 2

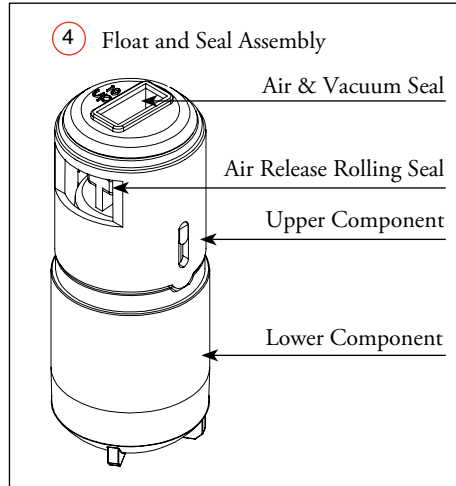
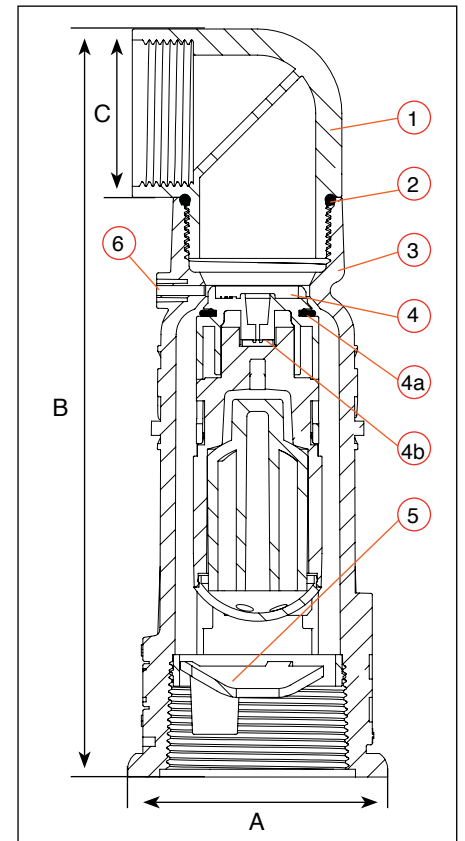

Fig. 1



TROUBLESHOOTING GUIDE

PROBLEM	REASON	SOLUTION
Discharge Outlet Leak	<ul style="list-style-type: none"> a. Debris caught in the Rolling Seal b. Debris caught between the Air & Vacuum Seal and the Body. c. Torn or cracked Rolling Seal and/or Air & Vacuum Seal. 	Perform: PERIODIC MAINTENANCE
Discharge Outlet Broken	Air valve was hit or mishandled.	Unscrew and replace.
Upper Drain Outlet	Upper Drain Outlet plugged with debris and won't drain the accumulated water.	Clean the hole with a pin and clean running water or a burst of air.

