



# NR-45 PN 16-64



## Removable Cover Check Valves for Consumer Connections to Potable Water Supply

### Description

Check valve with a swing-type disc, allows for one-directional flow and prevents liquid return to its source.

This valve has a removable lid which allows for the cleaning and maintenance of the valve without the need to remove it from the pipeline. The valve disc is connected to the valve body with an arm. Sealing is performed by the closing of the disc up against the valve seat, located at the inlet to the body.

The valve is suitable for use in potable water systems and is compliant with the Israeli Standard 5452

### Applications

- At consumer connections and valve crossovers
- Separation between the inlet and outlet to reservoirs and tanks
- General hydraulic usages such as filtration systems

### Operation

With flow stoppage, the disc drops down and closes the valve inlet. The static backpressure from the downstream water column closes the disc up against the valve seat which seals against backflow.

### Main Features

- The valve is manufactured in diameters: 2" – 12"
- A working pressure up to 16 bar (tested at 25 bar) with optional valve pressure ratings up to 64 bar.
- Maximum working temperature: 90° C.
- Blue epoxy-coated FBE coating in compliance with the NSF standard for potable water (Israeli Standard 5452).
- Cast body built to withstand effects of water hammer.

- Internal parts are made of durable non-corrosive materials, allowing for long term operation under harsh conditions.
- Removable upper cover allows for maintenance without the need to remove the valve from the pipeline.
- The disc is anchored at two points, preventing fluttering and turbulent flow
- Minimal energy losses and smooth water flow, achieved by the complete elevation of the disc into the upper cover opening.
- Vulcanized disc – for sealing at low pressure and preventing wear of the sealing area.
- Rubber stoppers restrain the movement of the disc at the maximum opening height; no contact between coated metal parts prevents damage to the coating.
- The valve can be installed horizontally only.
- Can be adapted to different fluid types.
- The valve can be manufactured according to any standard flange requirement.

### Valve Selection

- Metal disc sealing for work under extremely hard conditions or where there is rapid wear on the vulcanized disc.
- For working pressures higher than 40 bar, please contact the marketing department.
- Available with an EPDM Flexible Disc.

### Note:

For best suitability, it is recommended to send the fluid chemical properties along with the valve request. Upon ordering, please specify: model, size, working pressure, thread and flange standard and type of liquid.

### HEAD LOSS

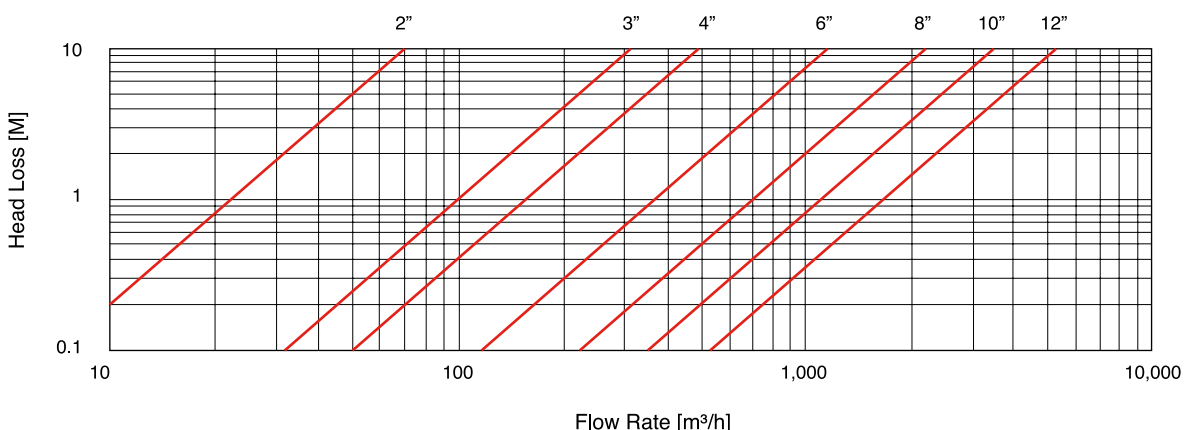

## DIMENSIONS AND WEIGHTS

Nominal Size	Dimensions mm			Weight Kg.
	A	B	C	
2" (50 mm)	121	141	108	3.9
3" (80 mm)	241	252	200	16.5
4" (100 mm)	262	284	220	25.4
6" (150 mm)	356	362	288	46.0
8" (200 mm)	421	455	374	93.6
10" (250 mm)	479	537	412	152.0
12" (300 mm)	553	623	490	248.0

2"

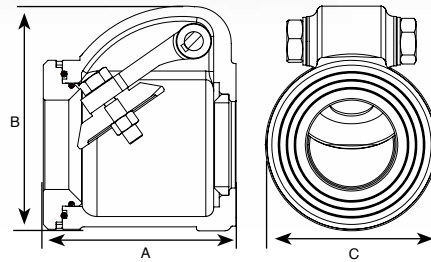

3" - 12"

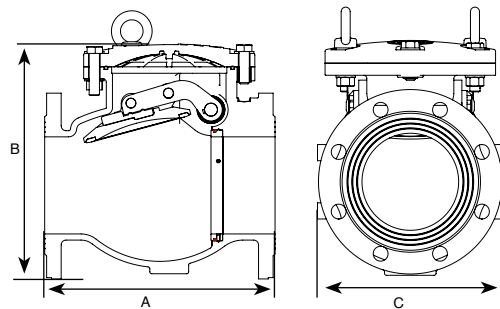

## PARTS LIST AND SPECIFICATION

No.	Part	Material
1	Lifting Ring	Steel Zinc Coated
2	Bolt	Steel Zinc Cobalt Coated
3	Washer	Steel Zinc Cobalt Coated
4	Cover	Reinforced Nylon
5	Disc	Stainless Steel 316 + Vulcanized Rubber
6	Stopper	EPDM
7	Cotter Pin	Stainless Steel 316
8	Pin	Stainless Steel 316
9	Disc Arm	Stainless Steel 316
10	Shaft	Stainless Steel 316
11	Washer	Stainless Steel 316
12	O-ring Seal	EPDM
13	Bearing	Bronze/Acetal
14	Bearing Key	Reinforced Nylon
15	Bolt	Stainless Steel 316
16	O-ring Seal	EPDM
17	Threaded Bushing	Stainless Steel 316
18	Body	Ductile Iron
19	Washer	Steel Zinc Cobalt Coated
20	Nut	Steel Zinc Cobalt Coated
21	O-ring Seal	EPDM
22	Body Seat	Stainless Steel 316
23	Body Seat Bolt	Stainless Steel 316

